

Balanced Photo-Detector (BPD)

Physics Basel (SP 1'023)

User's Manual | Revision 1.4 | October 2019

Features

- Optical power difference on two photodiodes
- Large bandwidth (-3 dB): 50 MHz
- Low dark noise (equivalent 800 nm optical power):
 @1 MHz: 1.7 pA/√Hz (3.2 pW/√Hz)
 @10 MHz: 5.1 pA/√Hz (9.5 pW/√Hz)
- Differential signal gain: 10^4 V/A
- Wavelength range: 320 nm to 1'000 nm
- Two large-area (d=0.8 mm) Si-PIN photodiodes Hamamatsu S5972 (84% QE @800 nm)
- Broadband signal output [10 V/mA]: ± 3.5 V @50 Ω
- Low gain [1 V/mA] monitor signals output: ± 10 V
- Up to 5 mA current per photodiode
- Electrically insulated mountable on an optical table
- Small size: L = 93 mm, W = 55 mm, h = 42 mm
- Low weight: 135 g
- ± 15 V Floating Power Supply (SP 874) included
- BNC adapter for monitor signals included

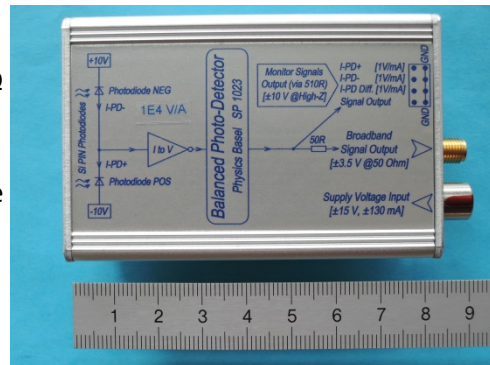

1 | Description

The *Balanced Photo-Detector (BPD)* measures the broadband difference signal of two photodiodes. It can be used in optical experiments as a low noise homodyne receiver dealing with frequencies up to 50 MHz. The monitor signals (I-PD+, I-PD-, I-PD Diff) can be used during optical adjustments and for slow control of the measurement system.

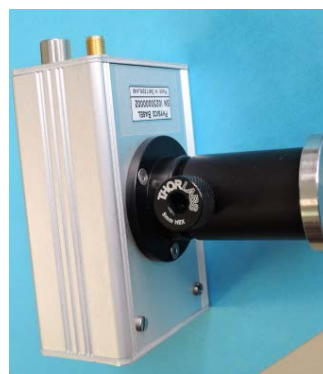
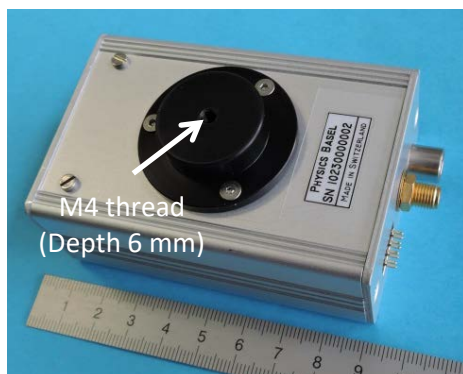

In the center at the bottom of the *BPD* an M4 mounting-thread (depth 6 mm) is available. Since this adapter is made out of plastic it electrically insulates the *BPD* housing from the optical table. The M4 thread allows attaching a metric post (e.g. ThorLabs TR30/M + PH40/M) for directly mounting the device on an optical table – see photos on the left.

2 | Block Diagram

The block diagram of the *BPD* is shown below; it might be helpful for understanding where the different *Monitor Signals* are derived from.

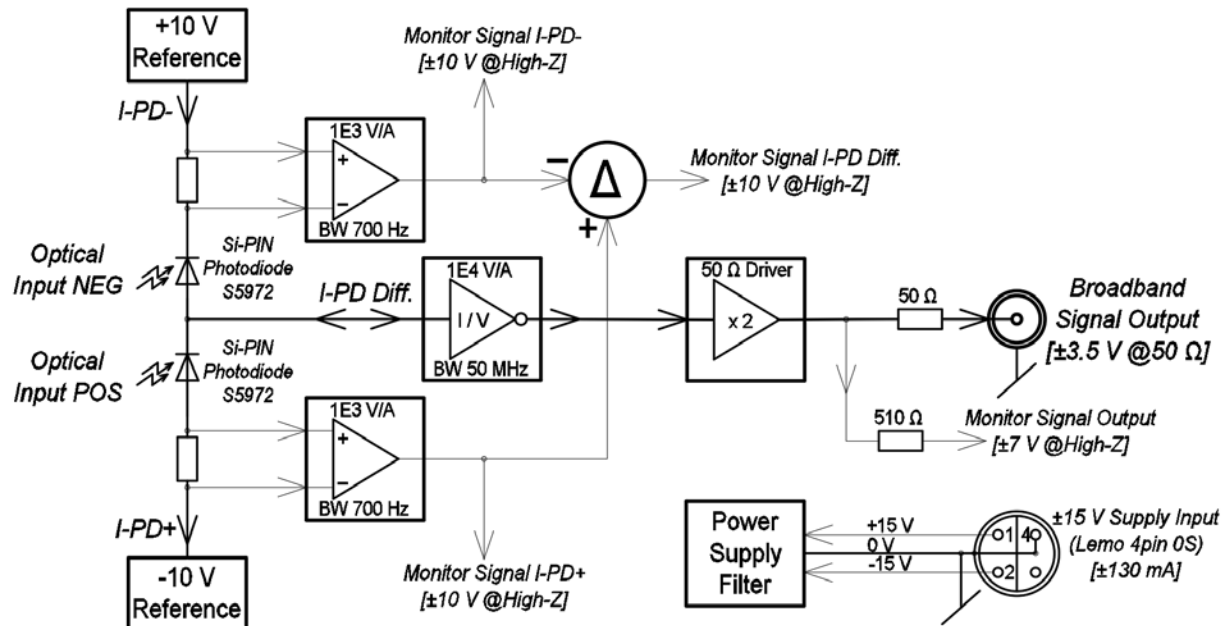

3 | Photodiodes – Transimpedance Amplifier

The *BPD* is equipped with high-speed silicon PIN photodiodes S5972 from the company Hamamatsu. This photodiode combines a large area (diameter=0.8mm → 0.5 mm²) with a small detector capacitance (3 pF @10 V bias) and low dark current (10 pA @10 V bias). A small detector capacitance is needed to reach a large bandwidth in combination with low noise performance. At a wavelength of 800 nm a quantum efficiency of 84% (photosensitivity 0.54 A/W) is reached by the S5972.

The photodiodes are mounted on sockets and can be replaced easily. On demand the *BPD* can be equipped with smaller area (0.12 mm²) photodiodes type S5973, also from Hamamatsu. The advantage of the S5973 is a smaller detector capacitance resulting in lower noise performance and slightly higher bandwidth (not yet tested).

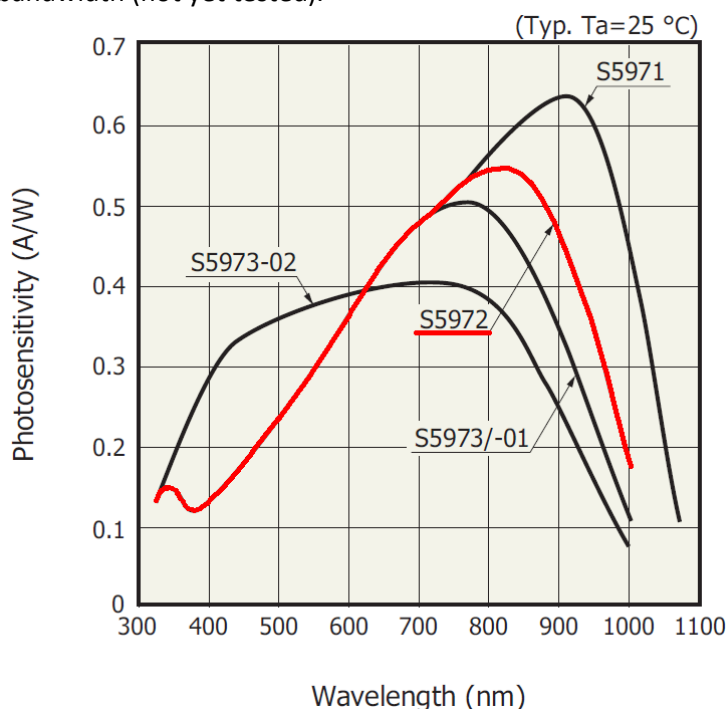

The absolute maximum power dissipation of the S5972 is specified with 50 mW. This corresponds to maximum 5 mA photocurrent at the applied bias voltage of 10 V. Then the optical power on the photodiode is 9.26 mW @800 nm. Since at the maximum power dissipation the photodiode may be damaged it is strongly recommended to work with optical power well below 4 mW.

The spectral photosensitivity of the S5972 is shown in the graph in red on the left. It covers a wavelength range from 320 nm to 1'000 nm. The maximum quantum efficiency of 84% is reached in the wavelength range of 740 – 760 nm.

The difference of the two photocurrents is amplified by a low noise and broadband transimpedance amplifier (I/V) with a gain of 10^4 V/A and a bandwidth of 50 MHz. This broadband signal output (SMA connector) can drive up to ± 3.5 V into a 50 Ohm load with a maximum slew-rate of 700 V/ μ s. The scaling of this fast output is 10 V/mA-difference-current. At a wavelength of 800 nm the scaling is 5.4 V/mW-difference-power. Therefore an optical power difference in the range of ± 648 μ W can be detected linearly; outside this range the amplifier saturates.

4 | Monitor Signals

The bandwidth of the first three monitor signals (I-PD+, I-PD-, I-PD Diff) is about 700 Hz and they are intended for DC-readout or slow-control. The load impedance must be larger than 10 kOhm and the signal-levels are up to ± 10 V. These monitor signals are dedicated to drive high-impedance loads such as oscilloscopes or voltmeters. Since the output impedance is 510 Ohm the measured voltage is divided by a factor of around ten, when terminated with 50 Ohm.

The scaling of the first three monitor signals (I-PD+, I-PD-, I-PD Diff) is 1 V/mA. At a wavelength of 800 nm the scaling in optical power is 0.54 V/mW. Since these three monitor signals can swing up to ± 10 V an optical power (difference) up to 18.5 mW could be detected linearly. Note, that working with optical power well below 4 mW is strongly recommended.

The fourth monitor signal (Signal Output) is a copy of the broadband output signal via a 510 Ohm resistor and the bandwidth is not restricted. When loaded with a high-impedance the signal can swing up to ± 7 V. The scaling is 20 V/mA-difference-current and at a wavelength of 800 nm the scaling corresponds to 10.4 V/mW-difference in optical power.



The monitor signals are fed out on an 8pin 2.54 mm post connector with two rows. Each monitor signal has its own ground pin. An adapter from the post connector to four BNC connectors is included (length 2 meters) – see photos left.

5 | Noise Performance

The measured dark input current noise density in a frequency range from 1 kHz up to 100 MHz of the *BPD* is shown below. Due to the capacitance of the photodiodes the noise density increases over frequency. This behavior comes from the frequency dependent noise-gain of the current-to-voltage converter. Between 5 MHz and 30 MHz the slope is around 0.45 [pA/√Hz] per 1 MHz. The maximum noise density of around 17 pA/√Hz is reached at 50 MHz which is the bandwidth of the transimpedance amplifier. This measurement is performed with no light (dark) on the photodiodes.

To convert the dark input current noise density into optical noise power density, the current noise has to be divided by the spectral photosensitivity. At 800 nm the photosensitivity of the S5972 is 0.54 A/W and the dark input current noise density of 1.7 pA/√Hz (@1 MHz) corresponds to an optical noise power density of 3.2 pW/√Hz.

Dark Input Current Noise Density VS. Frequency

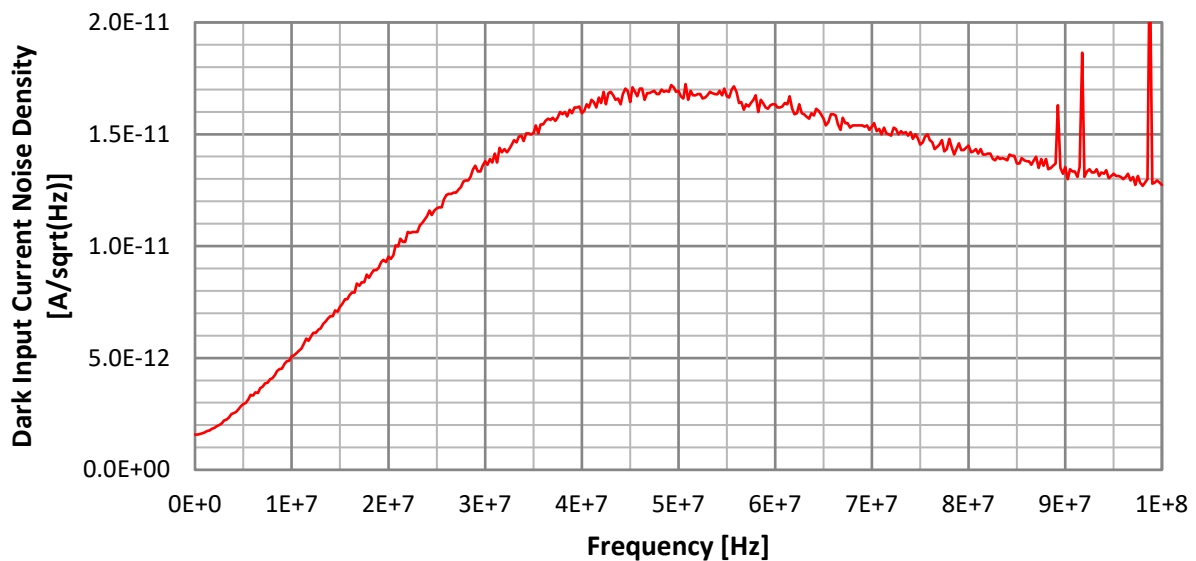

Light absorbed on a biased photodiode generates a leakage current which intrinsically carries shot noise. Given the DC leakage current through the photodiode (I_{DC} [A]) the shot noise current density (I_{shot} [A/√Hz]) can be derived from ($e_0 = 1.602E-19$ [As]):

$$I_{shot} = \sqrt{2e_0 I_{DC}}$$

In the perfect balanced photo-detector the same DC current (I_{DC} [A]) flows through both photodiodes and each of them generates its independent shot noise. So the balanced shot noise current density ($I_{shot\ balanced}$ [A/√Hz]) is given by:

$$I_{shot\ balanced} = 2\sqrt{e_0 I_{DC}} \quad \rightarrow \quad I_{DC} = \frac{(I_{shot\ balanced})^2}{4e_0}$$

At this DC current (I_{DC} [A], flowing through both photodiodes) the generated shot noise is equal to the dark noise. The total noise density is then increased by the factor of square root of two (+3 dB):

$$I_{DC} = \frac{(I_{dark\ noise})^2}{4e_0}$$

With the *BPD* the following balanced DC currents (optical power @800 nm) are needed to increase the noise floor by +3 dB – due to shot noise (i.e. to make the shot noise as strong as the dark noise):

@1 MHz	4.5 μA (8.3 μW)
@10 MHz	40.6 μA (75.2 μW)
@20 MHz	142 μA (263 μW)
@50 MHz	451 μA (835 μW)

6 | Mechanics

The overall dimensions of the *BPD* are approximately: Length = 93 mm; Width 55 mm; Height 42 mm. Below the exact dimensions [mm] of the *BPD* can be found. The two photodiodes are separated by 20 mm and they have their center position 26.6 mm above the plastic mounting plate with the M4 thread. In order to mount focusing lenses (or fiber connectors) in front of the photodiodes, three M2.5 threads (depth 2 mm) are centered (d=14 mm) around each photodiode. Lens or fiber mounts must be made by the users themselves.

The weight of the device (without cables) is about 135 g.

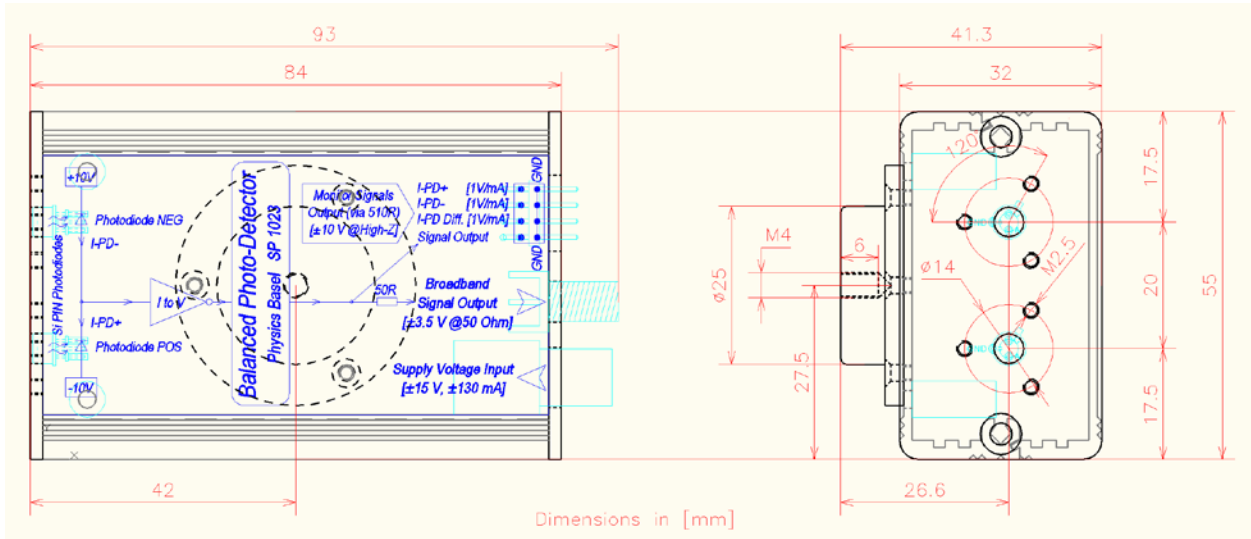

7 | Power Supply

The *BPD* must be supplied by a low noise and low ripple ± 15 V power supply. If possible, use the included ± 15 V Floating Power Supply (SP 874); this is a low noise linear regulated wall plug power supply. The maximal supply current drawn from the *BPD* is ± 130 mA. The housing of the *BPD* is connected to 0 V (GND) of the power supply.

A 4pin LEMO connector of the series 0S is used to connect the supply voltages; a LEMO connector of the type *FFA.0S.304.CLAC44* fits into the plug of the *BPD*. The pin connection is the following:

- PIN 1: +15 V, quiescent 40 mA / maximum 130 mA
- PIN 2: -15 V, quiescent 40 mA / maximum 130 mA
- PIN 3: not connected
- PIN 4: GND / 0 V / Housing